

Southern States Energy Board

December 12, 2018

Waste Isolation Pilot Plant

Bobby St. John
Deputy Manager, NWP Communications
Nuclear Waste Partnership

- Total Shipments received (since 1999)
 - 12,324
- Shipments since restart
 - 430
- Averaging 8-10 shipments/week
- Preparing to ship from Argonne National Laboratory
- In the future, get back to RH waste emplacement and continue ramp-up of CH waste shipments



- Safety Significant Confinement Ventilation System
- Assistant Secretary for Environmental Management
 - Anne White, June 14, 2018



Why a new Ventilation System

- 2050 current mission timeframe
- Numerous systems original to the facility
- Current air flow is inadequate to support full scale daily operations today & in the future



What are we doing now?

- Obtaining long lead procurement equipment
- Completed grading for the Trailer Complex and Pond for SSCVS
- Evaluating bids for majority of the SSCVS work
- Award construction contract
 - Critical Applications Alliance (\$135M)
- Start construction
 - December 2018
- Operational Turnover
 - May 2021



What makes up this project?

- \$288M of scope
- New Filter building
 - (55,553 sq ft)
- Salt Reduction Building
 - (24,960 sq ft)
- Fabrication Facility
 - (12,000 sq ft)
- Installation of a trailer complex
- Demolition of existing ventilation system

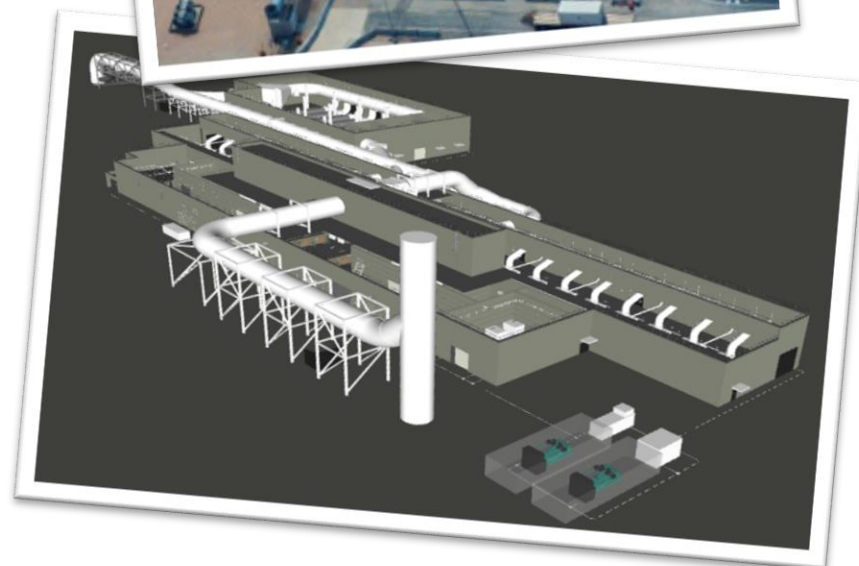

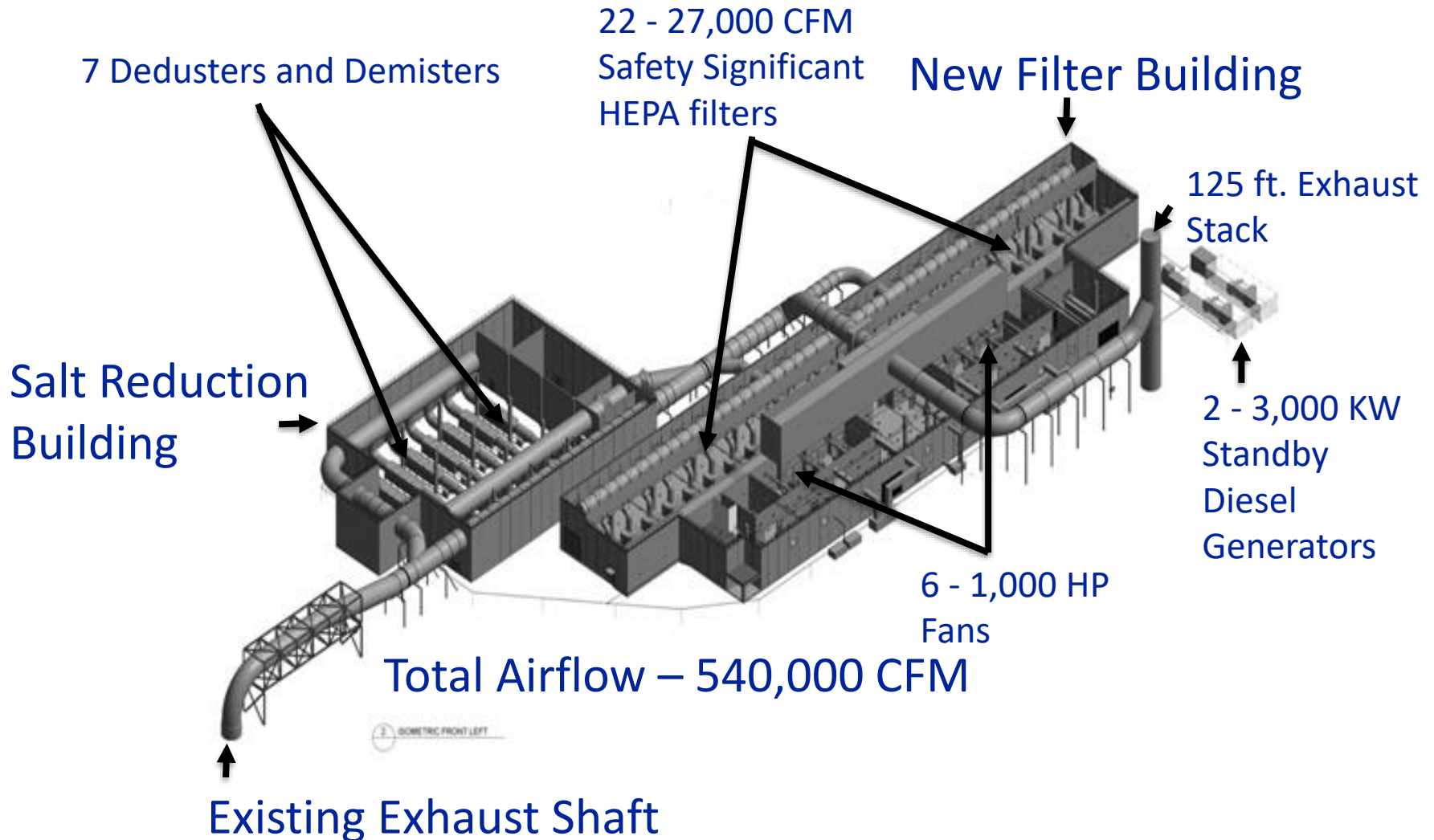

Questions?